



Emerald Supply Inc.

72000 Easy Rise Assist Lift User Manual



Dealers: This manual MUST be given to the user of the assist lift.

User: Before using this assist lift, read this manual and save for future reference.

Caution: DO NOT attempt to adjust or operate assist lift without carefully reading all instructions in this manual.

Table of Contents

1.	Introduction and Overview.....	1
1.1	Intended Use.....	1
1.2	Standard Symbols and Warning Labels Definitions.....	2
1.3	Safety Precautions	2
1.4	Life Expectancy.....	6
2.	Technical Specifications	7
2.1	General Features	7
2.2	Electrical Characteristics.....	7
3.	Equipment Assembly	8
3.1	Handling Procedures	8
3.2	Components.....	9
3.3	Assembling the Easy Rise Assist Lift.....	10
4.	Equipment Operation	15
4.1	Charging the Battery.....	15
4.2	Operating the Easy Rise Assist Lift	16
5.	Lifting and Moving the Patient.....	20
5.1	Preparing the Easy Rise Assist Lift for Use	20
5.2	Lifting and Moving the Patient	22
5.3	Transferring the Patient	22
6.	Maintenance	26
6.1	Maintenance Schedule	26
6.2	Detecting Wear and Damage.....	28
6.3	Lubrication	28
6.4	Checking and Tightening Mast Pivot Bolt	29
6.5	Replacing the Electric Actuator	29
6.6	Replacing the Boom/Hanger Bar	30
6.7	Replacing the Leg Cushion	30
6.8	Maintaining the Base Adjustment.....	31
6.9	Replacing the Casters/Forks.....	31
7.	Cleaning.....	32
8.	Troubleshooting Guide	33
9.	Limited Warranty.....	34
	Appendix	35

1.Introduction and Overview

The Easy Rise Assist Lift is designed to reduce risk of injury to patients and caregivers while moving and transferring. This assist lift also offers patients optimal comfort and a sense of safety when properly used. It is also user-friendly for caregivers, ensuring ease of use.

1.1 Intended Use

The Easy Rise 72000 Assist Lift is intended for use in within an institutional healthcare environment, e.g., hospitals, nursing homes, rehabilitation care and assisted living.

The assist lift is NOT a transport device. It is intended to transfer an individual from one resting surface to another (such as a bed to a wheelchair).

Moving a person suspended in a sling over any distance is NOT recommended.

DO NOT attempt any transfer without approval of the patient's physician, nurse or medical assistant.

This assist lift is intended for users who fully understood the content of this manual and is not intended for use by children.

1.2 Standard Symbols and Warning Labels Definitions

Signal words with symbols are used in this manual to highlight hazards or unsafe practices which could result in personal injury or property damage.

See the information below for definitions of the signal words and symbols.

Standard text - Normal character style used for “basic” information.

Boldface text - Emphasize a word or phrase.

Symbols - Represent different risks or hazards and information.



DANGER

Danger indicates an imminently hazardous situation which, if not avoided, will result in death or severe injury.



WARNING

Warning indicates a potentially hazardous situation which, if not avoided, could result in death or severe injury.



CAUTION

Caution indicates a potentially hazardous situation which, if not avoided, may result in property damage or minor injury or both.



IMPORTANT

Indicates a hazardous situation that could result in damage to property or equipment if it is not avoided.



TIPS

Gives useful tips, recommendations and information for ease of use.

1.3 Safety Precautions

1.3.1 Assembling the Lift



WARNING

DO NOT overtighten the mounting hardware as this will damage the mounting brackets.

1.3.2 Electrical and Radio Frequency Interference



WARNING

Thoroughly read through the battery/battery charger information prior to installing, servicing or operating your assist lift.

Most electronic equipment is influenced by Radio Frequency Interference (RFI). CAUTION should be exercised with regard to the use of portable communication equipment in the area around such equipment. If RFI causes erratic behavior, PUSH the Red Power Switch OFF IMMEDIATELY. DO NOT turn the Power Switch ON while transmission is in progress.

1.3.3 Operating the Lift



WARNING

DO NOT exceed maximum weight limitation of the assist lift. The weight limitation for the lift is 550 LBS.

ALWAYS keep hands and fingers away from moving parts to avoid injury.

Although two assistants are recommended for all lifting preparation and transferring procedures, our equipment will permit proper operation by one assistant. The use of one assistant is based on the evaluation of the health care professional for each individual case.

1.3.4 Using the Slings



WARNING

Use a sling advised by the individual's doctor, nurse or medical assistant for the comfort and safety of the individual being lifted.

DO NOT insert any kind of plastic back incontinence pad or seating cushion between patient and sling material that may cause the patient to slide out of the sling during transfer.

After each wash (in accordance with instructions on the sling), inspect sling(s) for wear, tears, and loose stitching. Bleached, torn, cut, frayed, or broken slings are unsafe and could result in injury, and should be DISCARDED immediately.

DO NOT alter slings.

Be sure to check the sling attachments each time the sling is removed and replaced, to ensure that it is properly attached before the patient is removed from a stationary object (bed, chair or commode).

If the patient is in a wheelchair, secure the wheel locks in place to prevent chair movements that could lead to potential falls.

When connecting slings to the assist lift, make sure there is sufficient head support when lifting a patient.

1.3.5 Lifting the Patient



WARNING

When using the lift, the legs **MUST** be opened to the maximum position and locked before lifting the patient.

The rear casters of the assist lift **MUST** be kept unlocked when lifting an individual. Locking the casters during lifting procedures could cause the lift to tip and endanger the patient and assistants. The unlocked casters during lifting procedures will allow the assist lift to stabilize itself when the patient is initially lifted from a chair, bed or any stationary object.

When the patient is elevated a few inches off a stationary surface and before moving the patient, check again to make sure that all hardware or straps are properly connected. If any attachment is **NOT** properly in place, lower the patient back onto the bed and rectify the issue.

Adjustments for safety and comfort should be made prior to moving the patient. Patient's arms should be kept inside of the straps.

During transfer, with patient suspended in a sling attached to the lift, **DO NOT** roll caster base over uneven surfaces that could cause the assist lift to tip over. Use steering handle on the mast at all times to maneuver the assist lift.

1.3.6 Transferring the Patient



WARNING

When the patient is elevated a few inches off a stationary surface and before moving the patient, check again to make sure that all hardware or straps are properly connected.

If any attachment is NOT properly in place, lower the patient back on to the bed and rectify the issue.

Wheelchair's wheels **MUST** be locked before lowering the patient into the wheelchair for transport.

Make sure the wheelchair weight capacity can withstand the patient's weight prior to loading the patient.

Be sure to check the sling attachments each time the sling is removed and replaced, to ensure that it is properly attached before the patient is removed from the bed or chair.

Mast pivot must be tight to ensure safe use of the assist lift. Bolt must be checked at least every six months in conjunction with periodic maintenance.

1.3.7 Performing Maintenance



WARNING

ONLY qualified personnel should carry out the lift maintenance.

DO NOT attempt to open the pre-sealed actuator or obtain local service, for it will **VOID** the warranty and might result in damage. Consult your dealer or manufacturer for further information.

After the first year of operation, the hooks of the swivel bar and the mounting brackets of the boom should be inspected every three months to determine the extent of wear. If these parts become worn, replacement must be made.

After the first year of operation, inspect the hanger/swivel bar and the eye of the boom (to which it attaches) for wear. If the metal is worn, the parts **MUST** be replaced. Make this inspection every six months thereafter.

Inspect the casters and axle bolts every six months to check for tightness and wear.

Regular maintenance of assist lifts and accessories is necessary to ensure proper operation. DO NOT overtighten mounting hardware. This will damage mounting brackets.

1.3.8 Disposal



WARNING

This product has been supplied from an environmentally aware manufacturer.

This product may contain substances that could be harmful to the environment if disposed of in places (landfills) that are not appropriate according to legislation.

Please be environmentally responsible and recycle this product through your recycling facility at its end of life.

1.4 Life Expectancy



The lift expectancy of the lift is five years, presuming that the product is used daily and in accordance with safety instructions and maintenance instructions stated in this manual.

2. Technical Specifications

These are average values, which may vary according to manufacturing tolerances.

2.1 General Features

Features	Value
Model Type	72000
Max. Hanger Bar Height	68"
Min. Hanger Bar Height	33.8"
Base Width (Open)	40"
Base Width (Closed)	26.8"
Base Height (Clearance)	4.1"
Base Length	43"
Caster Size (Front/Rear)	3" / 4"
Weight Capacity	550 LBS
Weight in Carton	128.9 LBS
Weight out of Carton	142.1 LBS

2.2 Electrical Characteristics

72000 - Electrical Characteristics	Value
Battery	24V DC
Charger Input	100-240V AC
Accessories (Optional)	Standalone Battery Charger
Battery Status	LCD Display
Approx. Lifts per Charge (Varies depending upon load and stroke)	10 Cycles per charge

3. Equipment Assembly

Use only parts supplied by Emerald Supply Inc. for assembly to ensure correct alignment of all parts for safe operation.

3.1 Handling Procedures

Check for any obvious damage to the carton. If damage is evident, notify the carrier and the dealer.

Carefully unpack the components from the shipping cartons.

Inspect all components. Examine exterior of the assist lift for nicks, dents, scratches or damages.

Unless the assist lift is to be used immediately, retain boxes, containers and packing material for use in storing until use of the assist lift is required.



CAUTION

DO NOT place other objects on top of the packaged assist lift.



Store the packaged assist lift in a dry area.

3.2 Components

Components Description	Piece
Caster Base	1
Mast/Actuator	1
Boom/Hanger Bar	1
Shifter Handle	1
Handle	1
Leg Cushion	1
Control Box and Hand Pendant	1
Charging Power Cord	1
Tool Kit	1

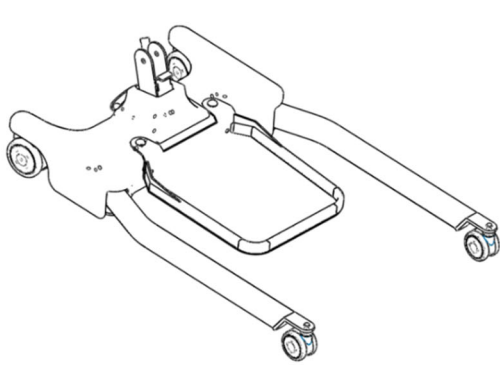

Caster base

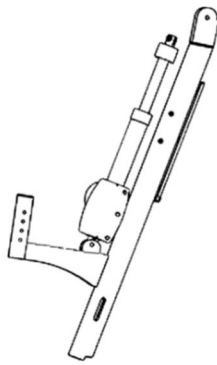

Mast/Actuator

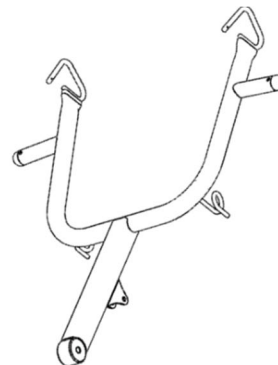

Boom/Hanger bar



Shifter handle

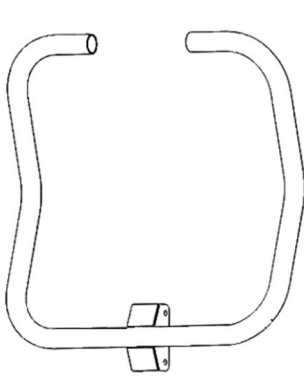

Handle

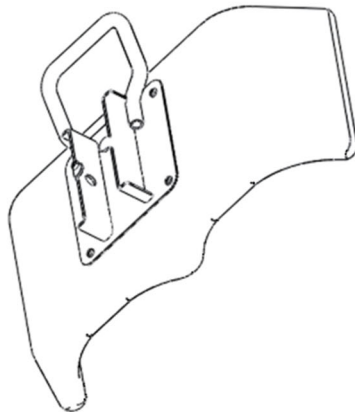

Leg cushion



Control box &
hand pendant



Charging
power cord

3.3 Assembling the Easy Rise Assist Lift



WARNING

DO NOT overtighten the mounting hardware as this will damage the mounting bracket.

3.3.1 Assembling the Mast/Actuator to the Base

1. Step on the locking levers to lock the two rear casters at the base.
2. Take the mast and position it in an upright position.

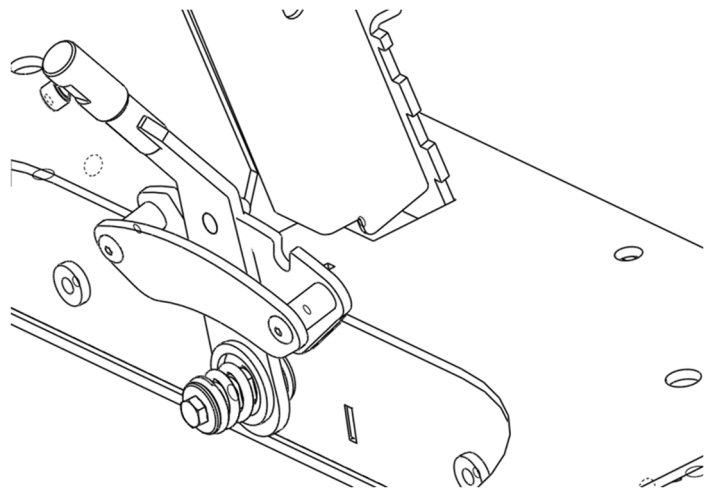
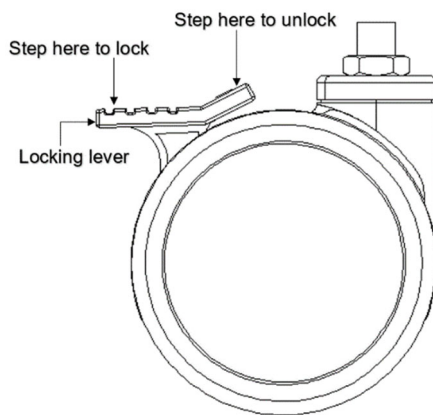

3. The notch on the mast should be facing back. Slide the mast onto the mounting bracket of the base.
4. Insert the shoulder bolt through the base and mast; secure with the nut properly.
5. Repeat the same procedure for the other pair of bolt and nut.

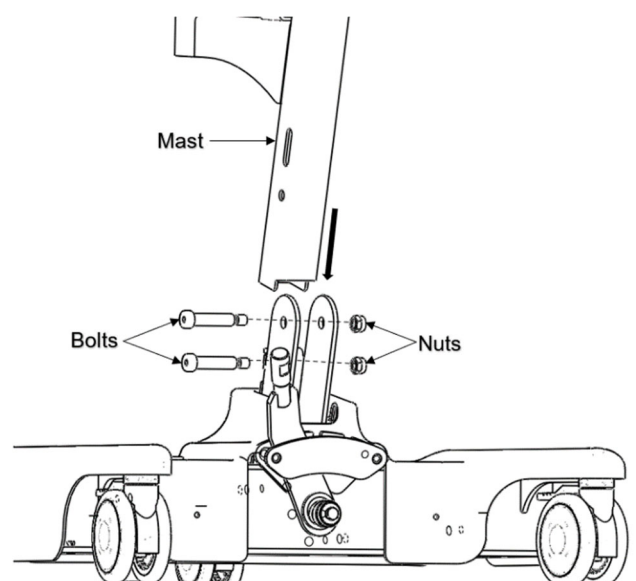

3.3.2 Assembling the Boom/Hanger Bar

1. Take the boom/hanger bar and align the holes on the U-shaped mounting bracket of the mast.
2. Insert the bolt through the washers and secure with a nut.

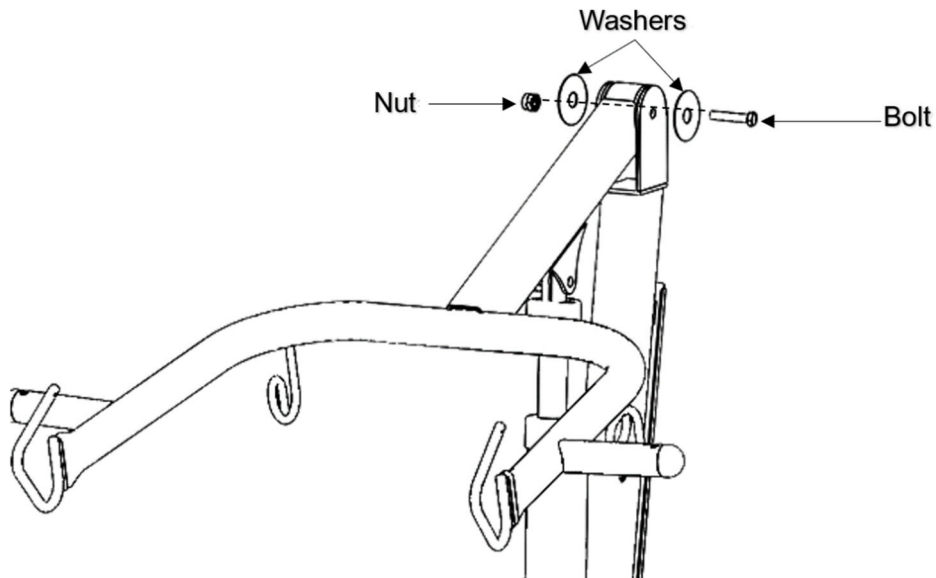

3.3.3 Assembling the Electric Actuator

1. Lift-up the boom and place it on your shoulder.
2. Align the holes on the top of the actuator and U-shaped mounting bracket.
3. Insert the bolt and secure with a nut.

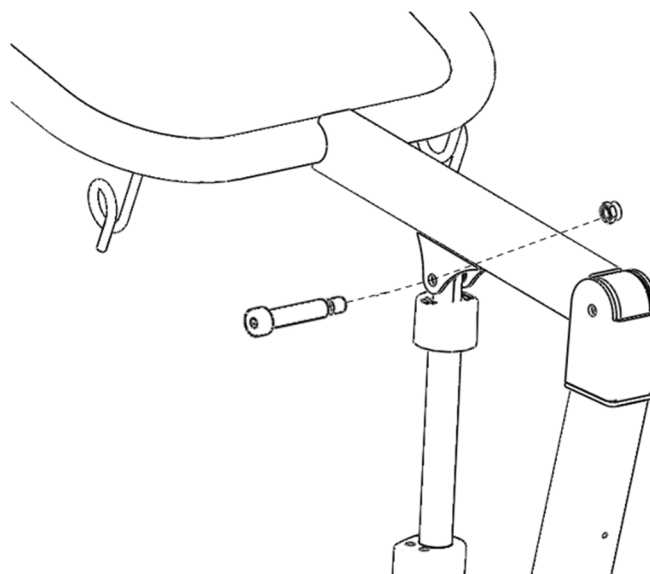

3.3.4 Installing the Handle

1. Take the handle; Make sure the open side is facing upward.
2. Align the holes on the handle mounting bracket and the holes on the top of the mast.
3. Insert the bolt and secure with a nut.
4. Repeat the same procedures for the bottom part.

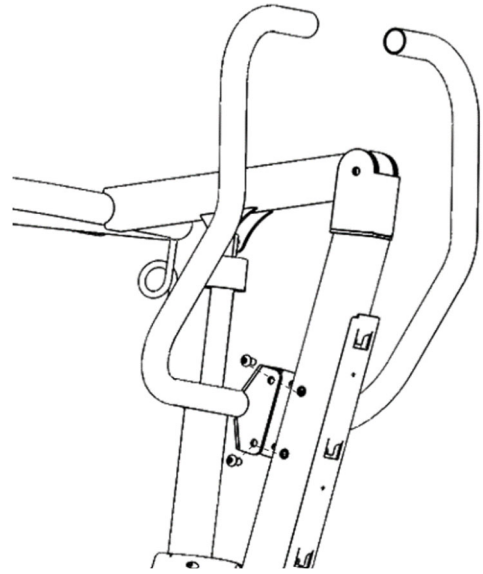

3.3.5 Assembling the Control Box to the Mast

1. Slide the control box onto the mounting bracket on the boom. Make sure the control box is held by the slide track.
2. Secure the control box (without battery) to the mounting bracket with screws.
3. Slide the battery onto the control box from the top.

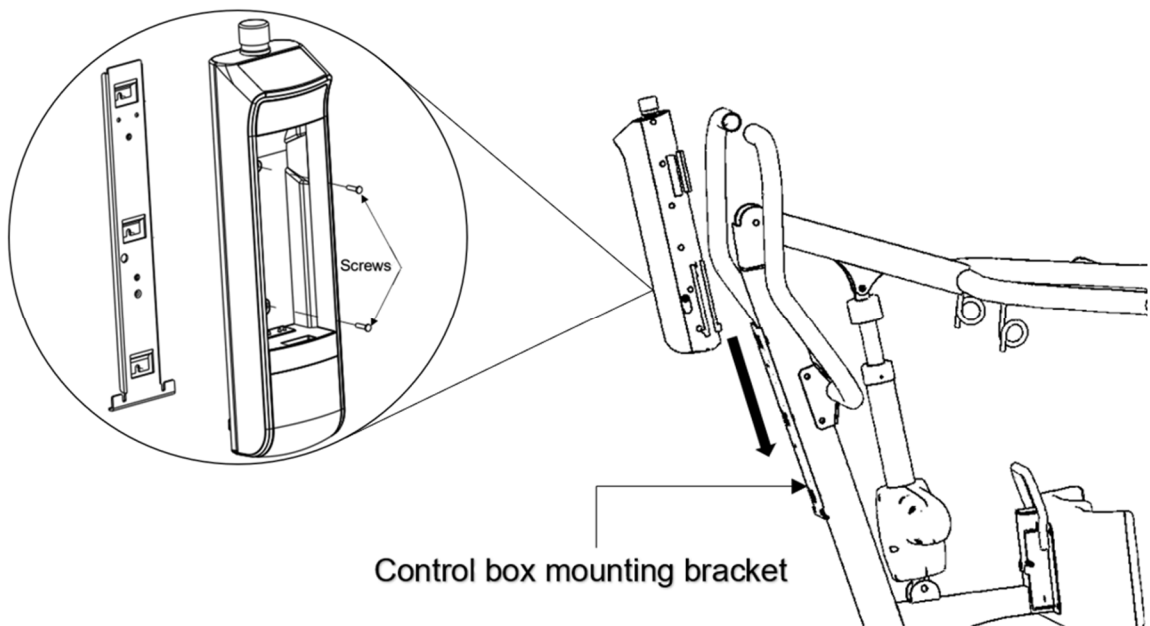

3.3.6 Connecting the Cords to the Actuator and Hand Pendant

1. Open the lid on the bottom section of the control box.
2. Connect the cords on to their corresponding ports. Both of the cords and ports are numbered for ease of installation.
3. Reinstall the lid.

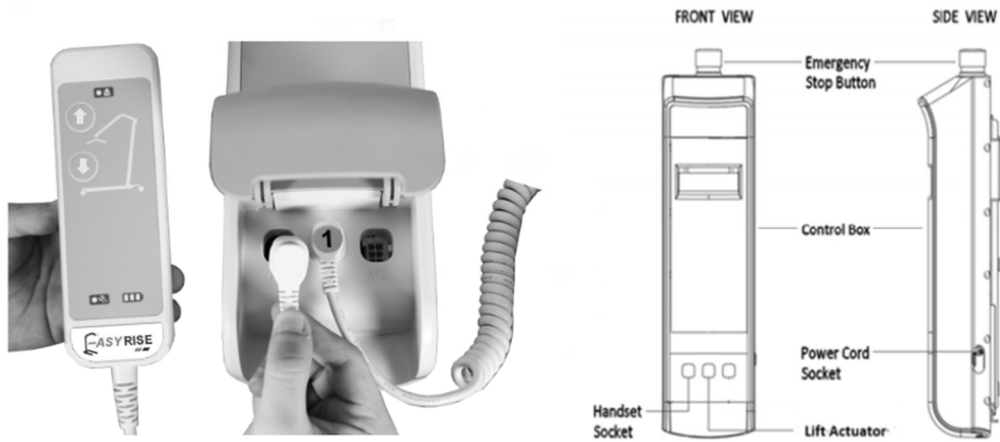

3.3.7 Installing the Shifter Handle

1. Remove the screw from the mounting barrel at the back of the base.
2. Insert the shifter handle into the mounting barrel assembly.
3. Align the hole and notch, insert the screw back and fasten it properly.

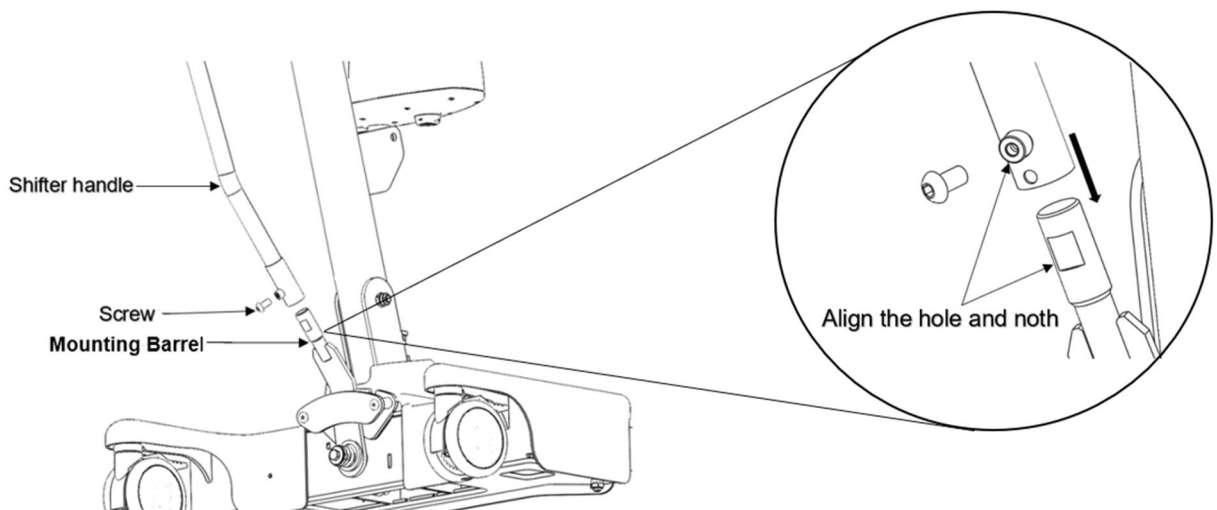

3.3.8 Installing the Leg Cushion

1. Take the leg cushion; align the holes on the mounting barrel of the mast.
2. Secure it properly with a bolt.

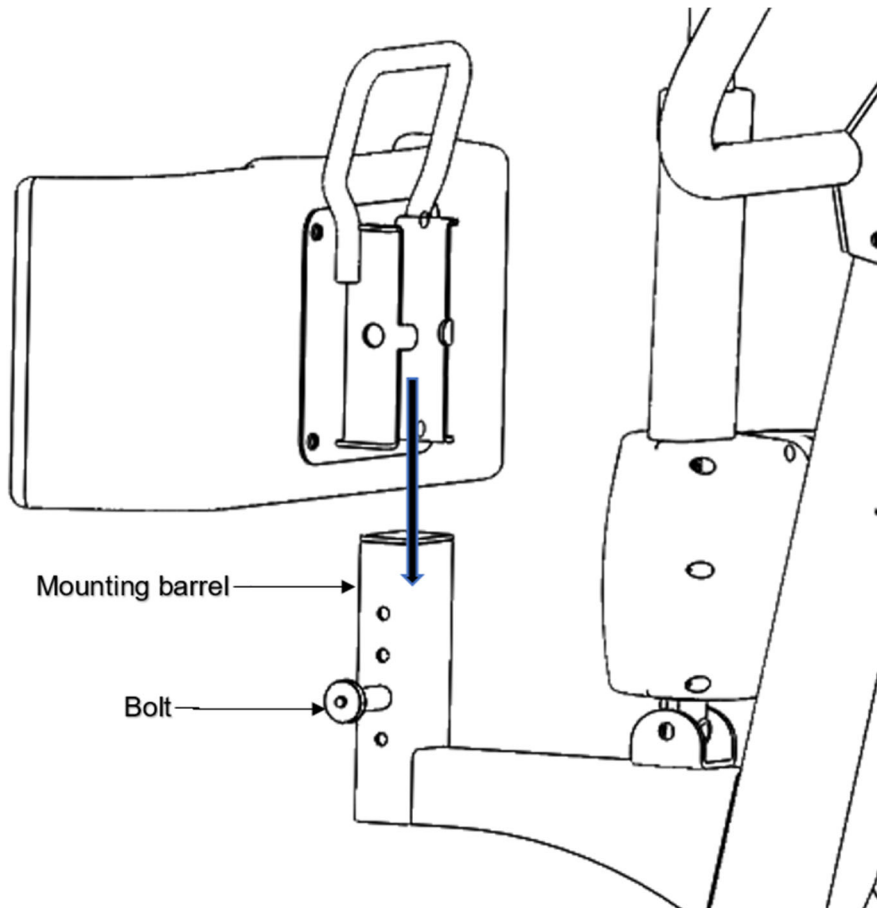

4. Equipment Operation

4.1 Charging the Battery



CAUTION

Keep the lift casters locked and the lift stationary.



It is recommended that the battery should be recharged daily to prolong battery life. The battery status can be viewed on the battery display on the hand pendant.

The lift will not be operable whilst the battery is being charged.

4.1.1 Charging the Battery with Power Cord

1. Use the charging cord provided in the carton, plug the pins into an appropriate grounded electrical socket.
2. Insert the other end of the power cord into the corresponding socket on the side of the control box.
3. Ensure the emergency button on the control box is disengaged when charging the battery.
4. The indication light on the hand pendant will illuminate to indicate the battery is being charged.

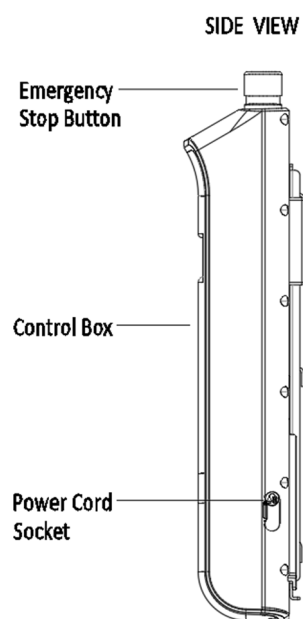

4.1.2 Charging the Battery with Standalone Charger (Optional)

1. Insert your hand through the recess on the front of the control box and pull out the battery.
2. Place the battery in the standalone battery charger.
3. Plug the power cord for the standalone charger into a grounded mains socket. Switch on the battery charger. The indicator light on the battery charger will turn red.

4. Once fully charged, the indicator light will turn green. Lift up on the strap handle on the top of the battery.
5. Lift the battery up and out away from the battery charger.
6. Reinstall the battery onto the control box. Make sure there is an audible click when closing the lid.

! **IMPORTANT**
The emergency stop on the control box must be activated, button **PRESSED IN**, when mounting the battery. If not, a potential power surge could damage the control box.

4.2 Operating the Easy Rise Assist Lift

4.2.1 Using the Control Box and the Hand Pendant

1. To raise the lift: Press ①
2. To lower the lift: Press ②
3. To confirm: Press ③
4. To reverse: Press ④

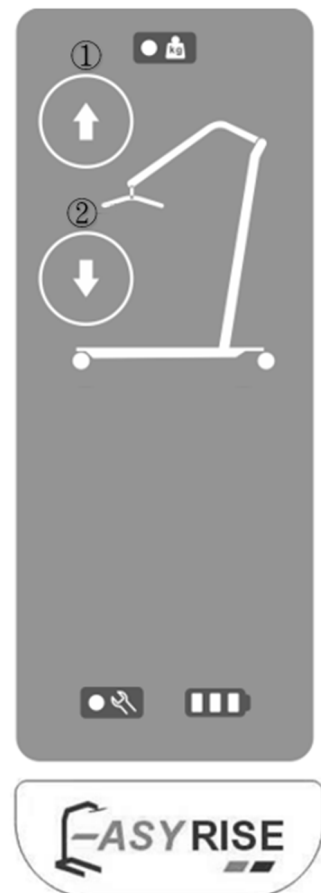
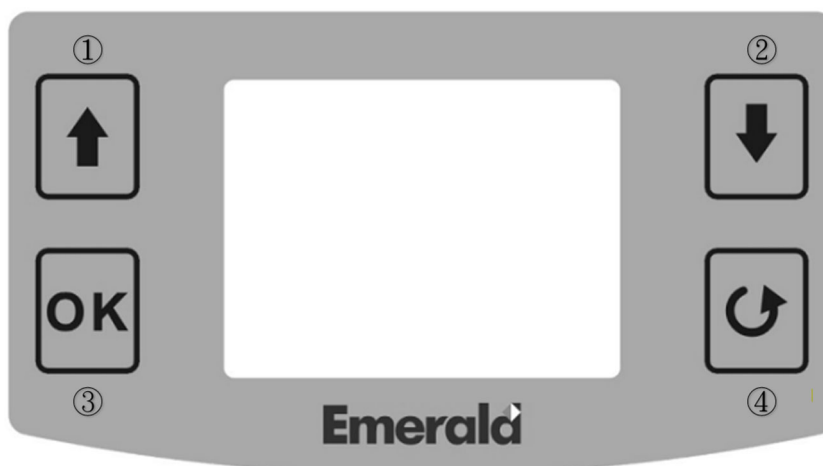



Press and hold ① and ② buttons on the control panel for about 5 seconds to enter the system setting interface. The system setting provides the functions of the overcurrent protection, maintenance cycle, historical data retrieval and couples more, which can be toggled using buttons ① and ②. Using buttons ③ and ④ to select or reverse.

- ◆ Interface 1: Overcurrent Protection Setting
- ◆ Interface 2: Maintenance Cycle Setting
- ◆ Interface 3: Historical Data Retrieval Setting
- ◆ Interface 4: Restore to Factory Setting
- ◆ Interface 5: Language Setting

4.2.2 Raising/Lowering the Assist Lift

1. Press button ① on the control panel or hand pendant to raise the assist lift.
2. Press button ② on the control panel or hand pendant to lower the assist lift.

4.2.3 Closing/Opening the Legs of the Caster Base

1. Stand at the rear of the lift and grasp the shifter handle with one hand and hold the handle with the opposite hand for balance.
2. Pull/push the shifter handle sideways away from the lift to release the lock pin from the mounting hole.
3. Swivel the shifter handle in a round motion towards the opposite side until you are able to secure the lock pin into the mounting hole.

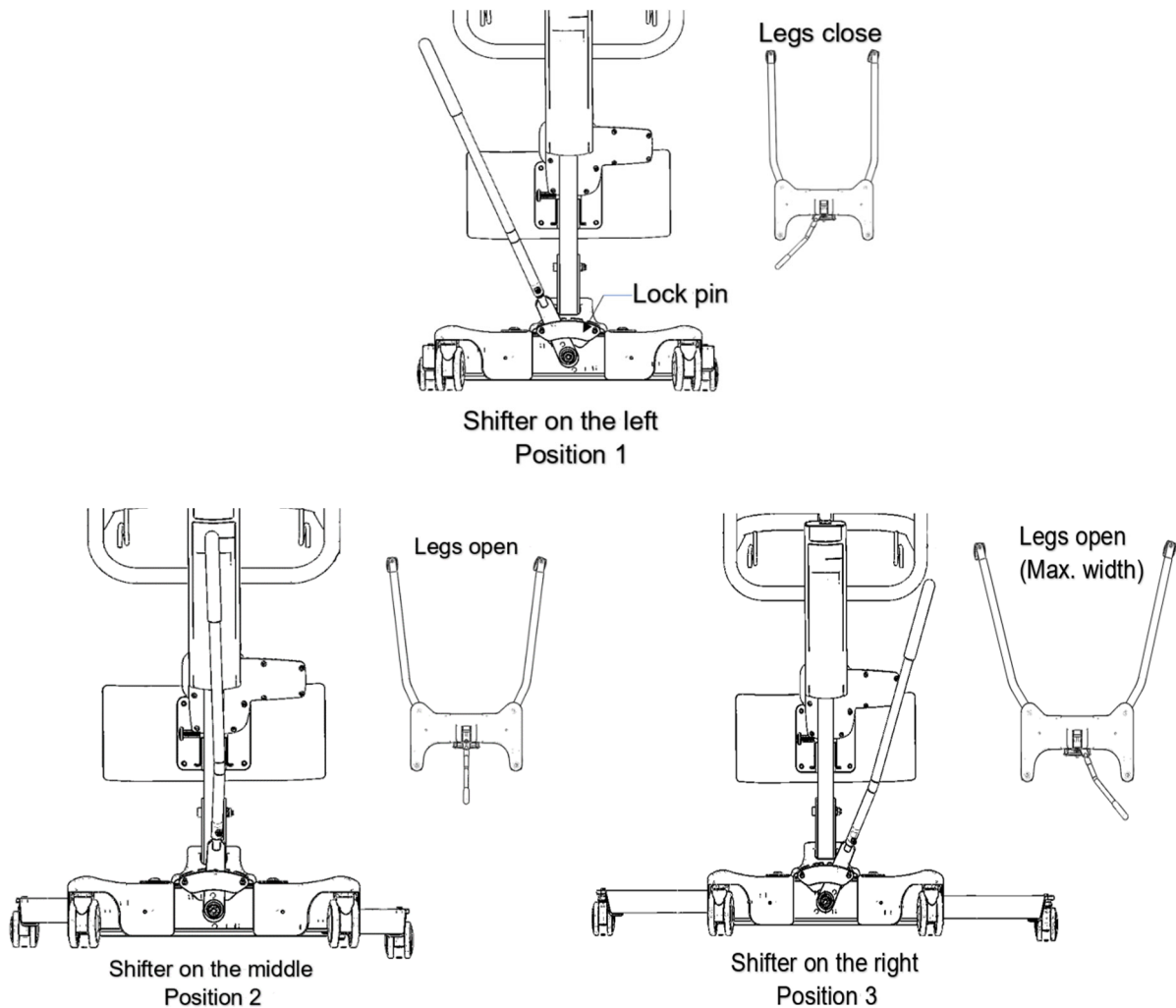

WARNING

The shifter handle must lock into its mounting hole to lock the legs in the full close/open position.

The shifter handle **MUST** be positioned completely into its mounting hole. **DO NOT** use the assist lift until shifter handle is properly seated and the legs of the assist lift are locked in place. Otherwise, injury and/or damage may occur.

4.2.4 Activating the Mechanical Emergency Release

All lift actuators are built with a Mechanical Emergency Release. The mechanical release enables the actuator to retract without power. To activate the emergency release, continue to rotate the emergency release knob clockwise, at the top of the actuator.

4.2.5 Activating the Emergency Stop

Press the RED/ORANGE emergency button on the control box to stop the boom assembly and patient from raising or lowering. Rotate the RED/ORANGE emergency stop button clockwise to disengage the emergency stop.

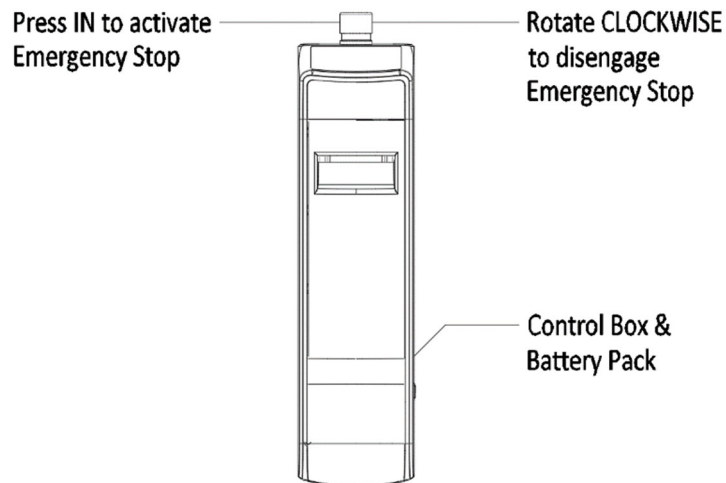

5. Lifting and Moving the Patient



IMPORTANT

The operation of the assist lift is an easy and safe procedure. **DO NOT** attempt any transfer without approval of the patient's physician, nurse or medical attendant.



WARNING

Thoroughly read the instructions in this manual, observe a trained team of experts performing the lifting procedures. Please practice the entire lift procedure with proper supervision to ensure that you are proficient in the operating steps to prevent any potential injuries to personnel.

5.1 Preparing the Easy Rise Assist Lift for Use

5.1.1 Positioning the Easy Rise Assist Lift

1. With the legs of the base open and locked, use the handle to push the assist lift into position.
2. Lower the assist lift for easy attachment of the sling.



IMPORTANT

The legs of the lift must be in the maximum open position. If it is necessary to close the legs of the lift to maneuver the lift under a bed, close the legs of the lift only as long as it takes to position the lift over the patient and lift the patient off the surface of the bed. When the legs of the lift are no longer under the bed, return the legs of the lift to the maximum open position.

5.1.2 Positioning the Sling

◆ At lying position:

1. Position the patient in the center of the bed and have them lie flat on their back.
2. Fold the sling in half (lengthwise) and place the sling beside the patient.
3. The top edge of the sling fabric (nearest to the patient's head)

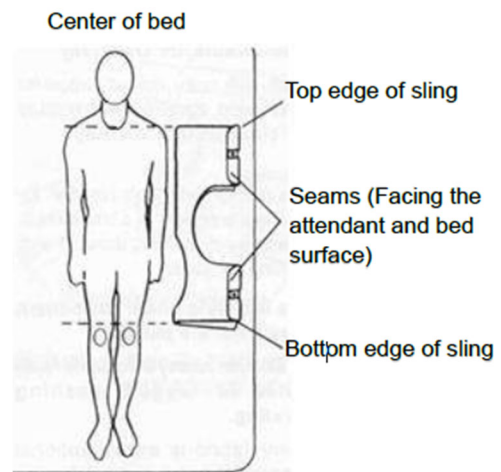

should be slightly above the armpit level of the patient. The bottom edge of the sling should then be a few inches above the back of the patient's knee.

4. With both attendants holding the patient, push the folded sling under the patient.
5. Roll the patient onto their back and they should be approximately centered on the sling.
6. You are now ready to attach the chains or straps to the sling.

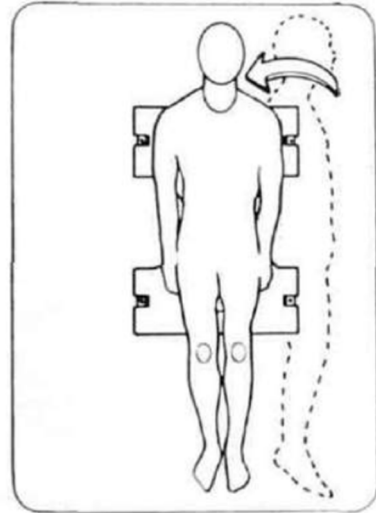

◆ At seated position:

1. Lean patient forward and set the folded sling behind the patient's back. Set the sling as far down as possible until it touches the back of the seat.
2. Open the sling, pull the bottom loop section of the sling under patient's thighs then cross the loops.
3. With the lift in position and boom lowered, place the straps of the sling over hooks of the swivel bar.



WARNING

Where the patient is seated in a wheelchair, the wheels **MUST** be locked when putting on the sling.

5.2 Lifting and Moving the Patient



WARNING

Before lifting or transferring the patient, the base legs **MUST** be locked in the open position for optimum stability and safety. **DO NOT** engage the rear locking casters when patient is in the lift.

1. Using the handle, push the assist lift underneath the bed.
2. With the sling securely attached to the lift, press the UP (▲) button to raise the patient above the bed. The patient should be elevated high enough to clear the bed and their weight supported by the lift.



WARNING

When the patient is elevated a few inches off the surface of the bed and before moving the patient, check again to make sure that all hardware or straps are properly connected. If any attachment is **NOT** properly in place, lower the patient back onto the bed and rectify the issue.

3. When the patient is lifted from the bed (with the patient's head supported), he/she will be raised to a sitting position.
4. When the patient is clear of the bed surface then swing their feet off the bed.
5. Using the handle and move the lift away from the bed.
6. When moving the assist lift away from the bed; turn the patient so that he/she faces assistant operating the assist lift.
7. Press the DOWN (▼) button lowering patient so that his/her feet rest on the base of the lift, straddling the mast.
8. With both hands firmly on the handle, pull the assist lift away from the bed and then push it from behind.

5.3 Transferring the Patient



CAUTION

The Easy Rise Assist Lift is **NOT** a transport device. It is intended to transfer an individual from one resting surface to another (such as a bed to a wheelchair). Moving a person suspended in a sling over **ANY** **DISTANCE** is **NOT** recommended.



WARNING

DO NOT attempt any transfer without approval of the patient's physician, nurse or medical attendant.



WARNING

Before lifting or transferring the patient, the base legs **MUST** be locked in the open position for optimum stability and safety. **DO NOT** engage the rear locking casters when patient is in the lift.

5.3.1 Transferring the Patient for Use of Bathroom Facilities



The slings with commode openings are recommended to be used with either a commode chair or a standard commode.

It is recommended that the sling remain connected to the swivel bar during the patient's use of either the commode chair or standard commode.



WARNING

The lift is **NOT** a transport device. Where it is difficult to maneuver the lift towards the commode or the bathroom facility is too far from the bed; the patient **MUST** be transported to a wheelchair first.

1. With the patient correctly positioned on the sling, attached the sling to the swivel bar.
2. The patient should be elevated high enough to clear the commode chair/standard commode and their weight supported by the lift.
3. With the help of both assistants, guide the patient onto the commode chair/standard commode.
4. Lower the patient onto the commode chair/standard commode leaving the sling attached to the swivel bar.
5. When complete, recheck for correct attachment and then raise the patient off the commode chair.
6. When patient is clear of the commode surface (using the steering handles), move the lift away from the commode chair/standard commode.
7. To return patient to bed, reverse procedures concerning lifting the patient, operation and sling attachment.
8. To return or place patient in a wheelchair, refer to "Transferring the Patient to a Wheelchair" section of this manual.

5.3.2 Transferring the Patient for Using a Bath

1. Move the patient from the bed onto the wheelchair, refer to "Transferring the Patient to a Wheelchair" section of this manual.
2. The patient should be elevated high enough to clear the wheelchair and their weight supported by the lift.

3. Lower the patient into the portable bathtub.
4. Disconnected the chains/straps from sling and reattach to the portable bathtub.
5. With the lift, raise the sides of the portable bathtub.
6. Bathe the patient.
7. To return to the bed, reverse procedures concerning lifting the patient, operation and sling attachments.

5.3.3 Transferring the Patient from and to a Wheelchair



WARNING

The wheelchair wheels **MUST** be **LOCKED** before lowering the patient into the wheelchair for transport.

1. The legs of the lift (with patient) shall be in open position.
2. Move the wheelchair into position.
3. Ensure the rear wheels of the wheelchair are locked to prevent further movement of the chair.
4. Position the patient over the seat with their face away from seat and their back against the back of the chair.



Use the straps or handles on the side and the back of the sling to guide the patient's hips as far back as possible into the seat for proper positioning.

5. Lower the patient by pressing the DOWN (...▼) button on the lift controller.
6. With one assistant behind the chair and the other operating the assist lift, the assistant behind the chair will pull back on the grab handle (on select models) or sides of the sling to seat the patient well into the back of the chair. This will maintain a good center of balance and prevent the chair from tipping forward.
7. Disconnect the sling from the assist lift.
8. To return to the bed, reverse procedures concerning lifting the patient, operation and sling attachments

5.3.4 Transferring the Patient from and to a Car



It is recommended that two assistants to help transferring a patient from a car to a wheelchair.

1. To transfer a patient away from a car, with the first assistant supporting the patient, the second assistant lower the boom of the assist lift until the hooks of the swivel bar are even with the roof of the car.
2. Attach the sling to the swivel bar.
3. Lift the patient up off of seat until straps are taut.
4. Turn patient with sling until legs are outside of car.
5. Lift up on legs with one hand and tilt the patient back with the other hand.
6. The second assistant should pull the assist lift away from the car until the patient is completely clear of the door frame.
7. Release the patient back to his/her normal sitting position in the sling.
8. Place patient in wheelchair, refer to "Transferring the Patient to a Wheelchair" section of this manual.
9. To transfer a patient to the car, reverse the above steps.

6. Maintenance

 For individual home use, a periodic inspection of the assist lift will reveal loose or worn parts, enhance smooth operation and prolong its lifespan.

6.1 Maintenance Schedule

Item	Initially	Institutional Inspect & Adjust (Monthly)	In-home Inspect & Adjust (6 Months)
The Caster Base			
Base opens/closes with ease.	○	○	○
Inspect for missing hardware.	○	○	○
Inspect casters and axle bolts for tightness.	○	○	○
Inspect casters for smooth swivel and roll.	○	○	○
Inspect and clear debris on casters.	○	○	○
Shifter Handle			
Smooth operation.	○	○	○
Locks adjustable base when shifter is engaged.	○	○	○
The Boom			
Inspect all hardware and swivel bar supports.	○	○	○
Inspected joints for wear.	○	○	○
Inspect for deformation.	○	○	○
Inspect the mast pivot joint under the rubber cover. Ensure the bolt is properly secured.	○	○	○

Item	Initially	Institutional Inspect & Adjust (Monthly)	In-home Inspect & Adjust (6 Months)
<p>The Hanger/Swivel Bar</p> <p>Inspect the bolt/hooks for wear and tear.</p> <p>Inspect the sling hooks for wear or deformation.</p>	<p>○</p> <p>○</p>	<p>○</p> <p>○</p>	<p>○</p> <p>○</p>
<p>The Mast</p> <p>Securely attached to the boom.</p> <p>Inspect for deformation.</p>	<p>○</p> <p>○</p>	<p>○</p> <p>○</p>	<p>○</p> <p>○</p>
<p>The Electric Actuator Assembly</p> <p>Inspect hardware on mast and boom.</p> <p>Inspect joints with mast and boom.</p> <p>Inspect for wear and tear. Return to the supplier where damaged.</p> <p>Cycle to ensure smooth quiet operation.</p> <p>Check the emergency release operates.</p>	<p>○</p> <p>○</p> <p>○</p> <p>○</p> <p>○</p>	<p>○</p> <p>○</p> <p>○</p> <p>○</p> <p>○</p>	<p>○</p> <p>○</p> <p>○</p> <p>○</p> <p>○</p>
<p>Sling and Hardware</p> <p>Check all sling attachments EACH TIME IT IS USED* to ensure proper connection and patient safety.</p> <p>Inspect sling fabric for wear.</p> <p>Inspect strap for wear.</p>	<p>○*</p> <p>○</p> <p>○</p>	<p>○*</p> <p>○</p> <p>○</p>	<p>○*</p> <p>○</p> <p>○</p>

6.2 Detecting Wear and Damage

When examining the equipment, attention should be paid to all stressed parts, such as slings, swivel bar and any pivot for slings for signs of cracking, fraying, deformation or deterioration. Replace any defective parts immediately and ensure that the lift is not used until repairs are made.

6.3 Lubrication

Minimum maintenance is required for the lifts. A check and lubrication every six months should ensure continued safety and reliability.

The lift and slings should be kept clean and in good working order. Any defect should be noted and reported to your dealer as soon as possible.

The casters MUST swivel and roll smoothly. A light grease (waterproof auto lubricant) may be applied to the ball bearing swivel of the casters once a year. Apply more frequently if the casters are exposed to extreme moist conditions.

Refer to the below figure for lubrication points. Lubricate all pivot points. Wipe all excess lubricant from lift surface.

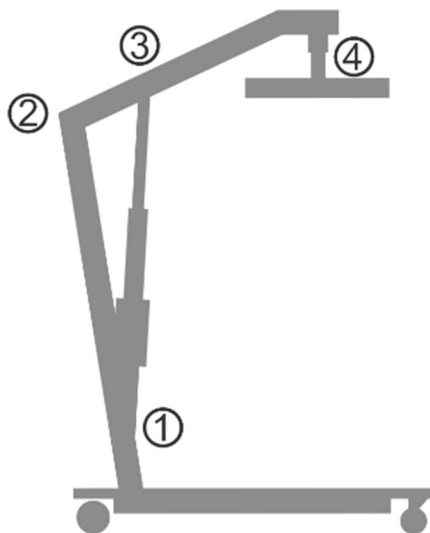

1. Mast Mounting Bracket
2. Boom/Mast Mount
3. Boom Mounting Bracket
4. Hanger Bar

6.4 Checking and Tightening Mast Pivot Bolt

1. Inspect the pivot point, check that the bolt is through the bracket and the nut is tight and secure.
2. If needed, do one or more of the following:
 - Tighten the nut and back-off the nut 1/8 of a turn.
 - Replace the nut.

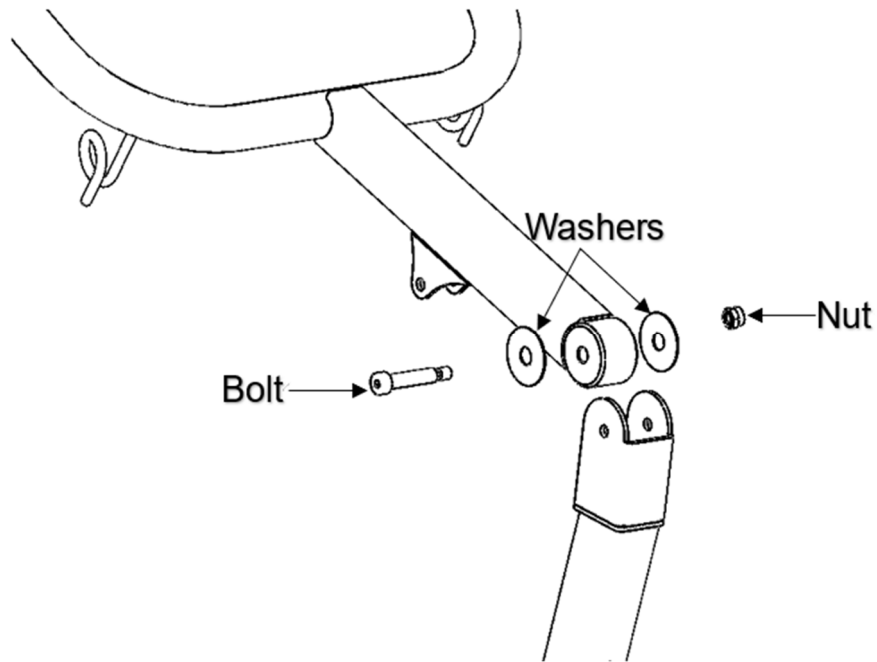

6.5 Replacing the Electric Actuator

1. Remove the shoulder bolt, nut, and washer that secure the electric actuator to the mast mounting bracket.
2. Rest the boom on your shoulder and remove the bolt, nut, washer, and plastic bushing from the boom mounting bracket.
3. Remove the electric actuator.
4. Reverse the procedure for new actuator installation.

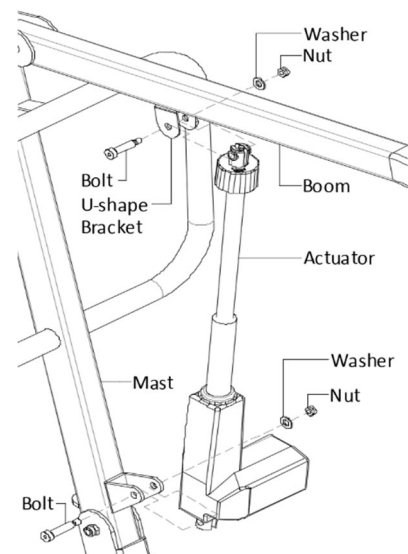

6.6 Replacing the Boom/Hanger Bar

1. The boom/hanger bar comes attached to the mast.
2. Loosen the bolt and remove existing hardware.
3. Replace the new boom/hanger bar.

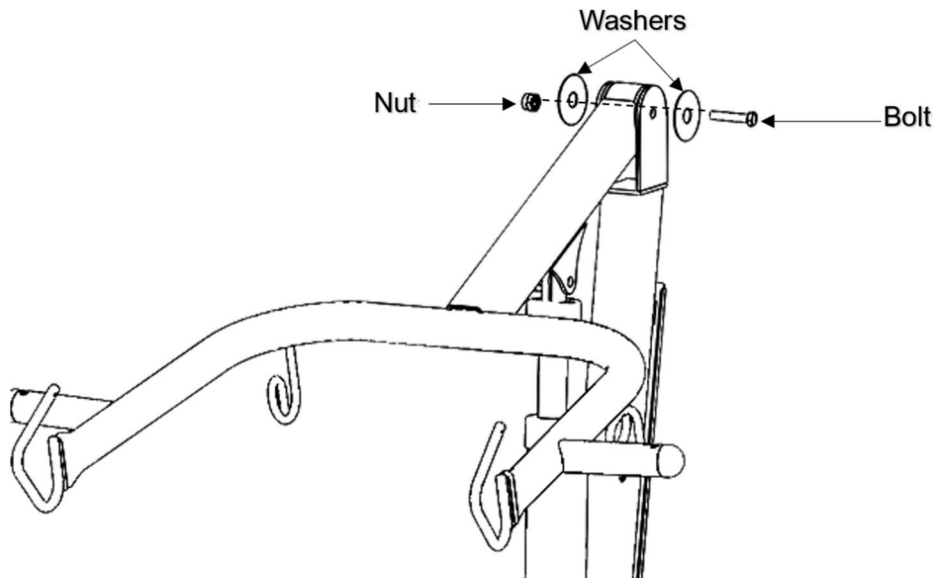

WARNING

After the first year of use, the hooks of the hanger/swivel bar and mounting brackets of the boom should be inspected every six months determine the extent of wear.

If these parts become worn, replacement must be made.

6.7 Replacing the Leg Cushion

1. Loosen the bolt and nut; remove it from the mast.
2. Inspect the mounting bracket and barrel.
3. Replace a new leg cushion if the parts are worn.

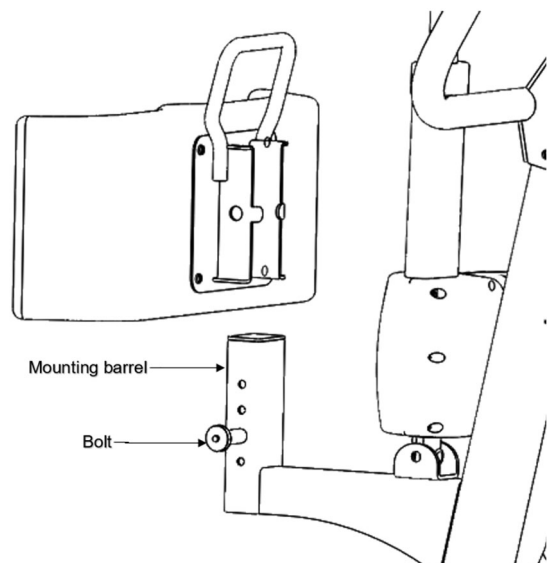

6.8 Maintaining the Base Adjustment

The base adjustment should not require any attention other than:

1. Check the squareness of the legs when in the closed position.
2. Place a square on the inside of the legs and base to determine the 90° alignment.
3. Loosen the nut on the linkage rod, rotate the linkage rods until 90° alignment is achieved. Tighten the nut.

6.9 Replacing the Casters/Forks

6.9.1 Replacing the Rear and Front Casters

For Rear Casters:

1. Turn to loosen or fasten it with the nut.

For Front Casters:

1. Simply turn to loosen or fasten the caster.

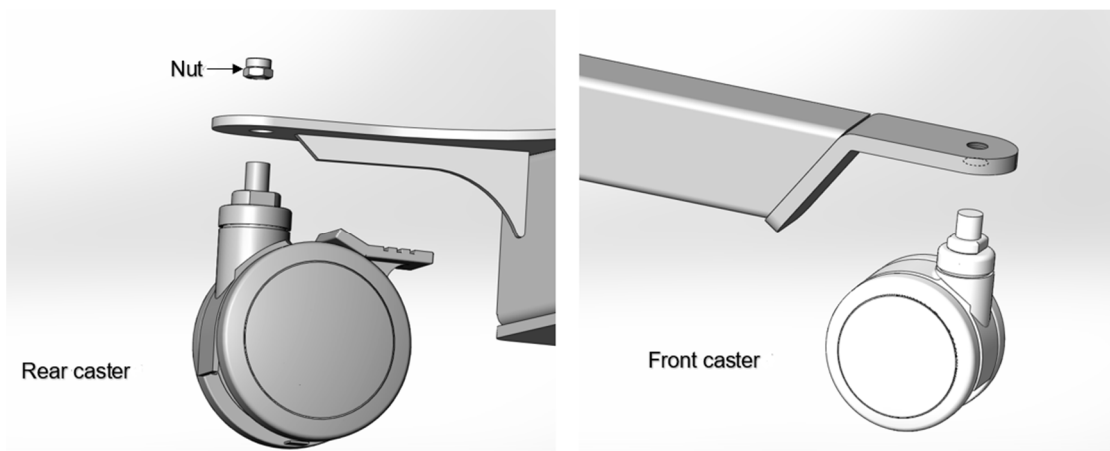

6.9.2 Replacing Casters Forks

1. Turn and place the lift on its side.
2. Remove the front or rear caster from the lift. Refer to Section 6.8.1.
3. Unscrew the existing fork from the base.
4. Install the new fork onto the base.
5. Install the front or rear caster onto the lift. Refer to Section 6.8.1.

7.Cleaning



Regular cleaning and disinfection can ensure the lift remains sanitary and extend the life expectancy of it. Follow the recommendations detailed in this manual to maintain your assist lift at an optimal hygiene standard.



CAUTION

Make sure the power is off and stow the power cord properly.

Lock the caster base to ensure the assist lift cannot move.

Never clean the lift by pouring water on it, nor with high-pressure hoses nor in tunnel washes.

Avoid excess water on the electric actuator, control box, hand pendant and power cord.

Do not scrape surfaces when cleaning the tough stains.

Never use abrasives, cleaning powder or cleaning pads that may damage components.

Use a slightly damp soft cloth along with standard disinfectant to wipe downward gently; yet, avoid excessive use of liquid.

Auto wax or furniture polish are allowed to use to help maintain the sparkling finish over a long period of time.

Always dry the assist lift thoroughly and carefully test it after it has been cleaned.

8. Troubleshooting Guide

Symptoms	Faults	Solutions
Actuator idle when lift buttons are pressed.	<p>Battery Low.</p> <p>Hand pendant or actuator connector loose.</p> <p>Red emergency stop button pressed in.</p> <p>Battery not connected properly to control box.</p> <p>The connecting terminals are damaged.</p> <p>Actuator in need of service or load is too high.</p>	<p>Recharge battery with power cord or standalone charger.</p> <p>Ensure tight connection of all connectors to control box.</p> <p>Rotate the emergency button Clockwise until it pops out.</p> <p>Dismount and remount the battery to control box.</p> <p>Replace the battery pack. Contract your supplier.</p> <p>Contact your supplier for actuator maintenance.</p>
Assist lift feels loose.	<p>Mast/Base joint loose.</p> <p>Tie - Rods are loose.</p>	Refer to Section 3.3 & 6.4.
Casters/Brakes noisy or stiff.	Debris or fluff in bearings.	Replace casters.
Noisy or dry sound from pivots.	Needs lubrication.	Lubricate your lift.
Unusual noise from actuator.	<p>Actuator is worn or damaged.</p> <p>Spindle is bent.</p>	Replace the actuator. Contact your supplier.
Lift arms will not lower during a power retraction.	Shoulder bolt at the junction of the boom and mast may not be properly installed.	Tighten the mast and boom pivot bolt.



If problems persist following the above remedial procedures, please contact your dealer or the manufacturer.

9. Limited Warranty

The Easy Rise 72000 Assist Lift is built to exact standards and carefully inspected prior to shipment. This limited warranty is an expression of our confidence in the material and workmanship of our products and our assurance to our customers for years of dependable services.

This warranty is extended only from original date of purchase and for use by the original purchaser. The warranty periods are as follows,

Structural steel: 5 years

Mechanical components: 1 year

Electronic components: 1 year

Non-durable components, such as rubber accessories, casters, hand pendant and grips, which are subject to normal wear and require periodic replacement, are not included in this warranty.

If within such warranty period any such product shall be proven to be defective, such product shall be repaired or replaced, at Emerald's option.

This warranty does not include any labor or shipping charges incurred in replacement part installation or repair of any such product.

The warranty does not cover normal wear and tear, or damaged caused by user misuse, use in unsuitable environmental conditions, abuse or failure to maintain or store the product in accordance with user and service instruction.

Any alteration, modification, or repair unless performed by, or authorized in writing by, Emerald Supply Inc., will void this warranty. Defect or damages caused by unauthorized parts or attachments, will also void this warranty.

This warranty shall not apply to serial numbered devices if the serial number has been removed, altered or defaced.

When requested by Emerald Supply Inc., parts must be returned for inspection at the customer's expense. Credit will be issued only after inspection.

For any warranty claims or service information, please contact us at:

Emerald Supply Inc.
Brooklyn, NY
888-363-5563
www.emeraldsupply.net

Emerald

Emerald Supply Inc.

888-363-5563

www.emeraldsupply.net